

# BAUER BG 30 H

Drilling Rig  
Base Carrier BT 85

 Energy-Efficient  
Power **EEP**



The Bauer drilling rig stand for multifunction equipment for a variety of foundation construction systems. The selection between two model ranges allows an optimum choice for differing project or transportation requirements.

Specific highlights of the drilling rigs are:

- High safety standards
- Environmental sustainability, economic efficiency and performance
- Easy transport and short rigging time
- High quality standard
- Long lifetime and excellent resale value

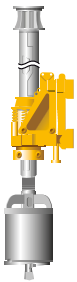

**Kelly drilling**



**Cased Kelly drilling**  
Casing Installation with BTM



**CFA**  
Continuous Flight  
Auger Method



**FDP**  
Full Displacement Piling  
(standard or lost bit)



**FoW**  
Front-of-wall method



**VD**  
Vibro Displacement



## The Drilling Rig BG 30 H (BT 85)

Max. drilling diameter: 2,500 mm  
 Max. drilling depth: 64.7 m  
 Max. torque: 300 kNm  
 Max. height: 25.5 m  
 Engine: Volvo TAD 13 345/405 kW



**Cased Kelly drilling**  
 Casing installation  
 with casing oscillator

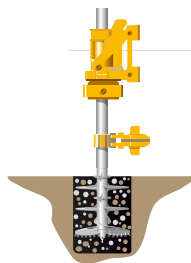

**SCM/SCM-DH**  
 Single column mixing

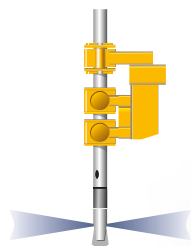

**HPI**  
 Jet grouting

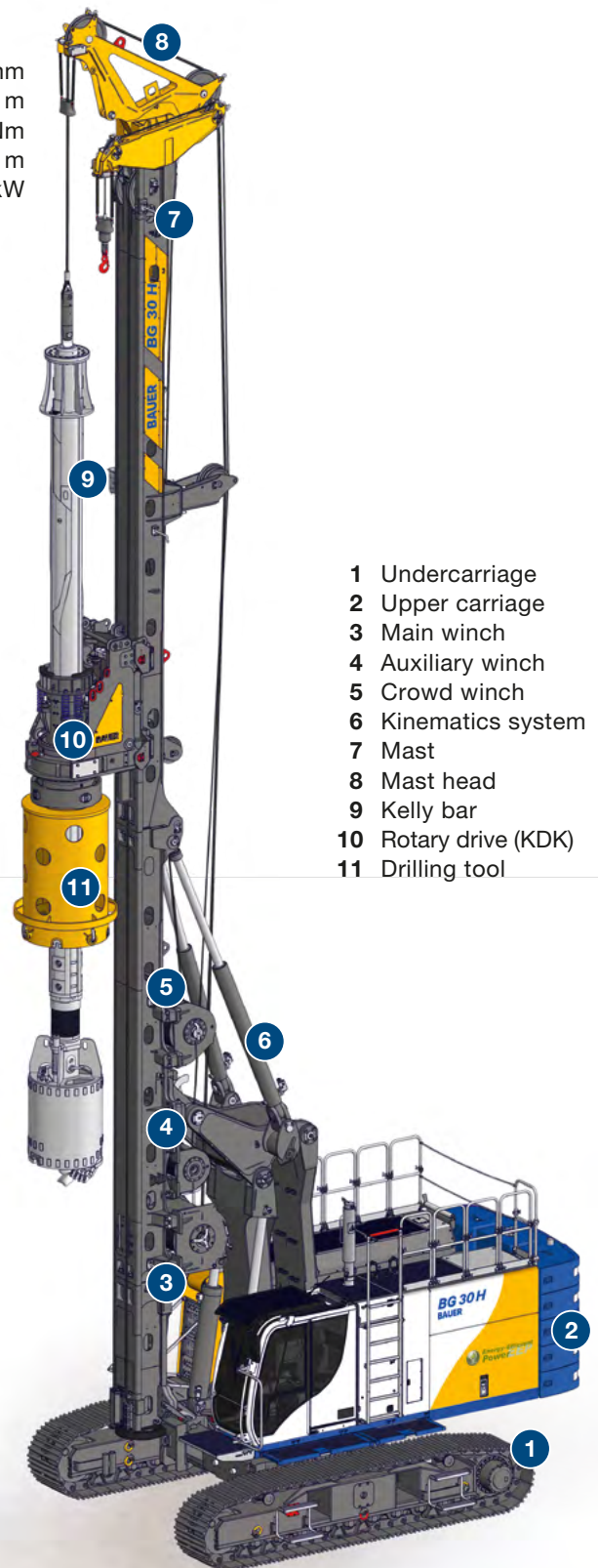

- 1 Undercarriage
- 2 Upper carriage
- 3 Main winch
- 4 Auxiliary winch
- 5 Crowd winch
- 6 Kinematics system
- 7 Mast
- 8 Mast head
- 9 Kelly bar
- 10 Rotary drive (KDK)
- 11 Drilling tool



**Modern, ergonomic operator's cab**

- FOPS compliant with additional protective roof guard
- Premium operator seat, air-sprung, heatable and air-conditioned
- Joystick controls with high functionality
- B-Drive for multi-functional potentiometer input

**Powerful Volvo engines**

- TAD 13 (345 kW UN/ECE R96\* or 405 kW EU Stage V,
- EPA/CARB Tier 4 final)
- Diesel particulate filter in exhaust emission EU Stage V,
- EPA/CARB Tier 4 final
- Low noise emission
- Worldwide CAT service partners



**Safety equipment**

- Integrated service platforms in the upper carriage for easy and safe maintenance work
- Retractable grating on side of cab
- Guardrails on the upper level (foldable for transport)
- Rear view cameras



- Reduction of fuel consumption by up to 30%
- Increased productivity through improved efficiency
- Significantly reduced noise levels
- Tried and proven suitability for practical application
- Optimized parallel operation of main and auxiliary consumers

\* Exhaust emission equivalent EPA Tier 3 and EU Stage III A

### Variable stackable counterweight elements

- Constant tail radius (irrespective of number of counterweights)
- Low weight of individual elements (4.9 t or 2.5 t)
- Flexible arrangement for various applications
- Mounting and demounting possible with the drilling rig
- Transport of the machine possible without removing counterweights



Single Pass **SPEX**  
Extreme

### Flexible mast concept

- Extension package Single Pass Extreme (SPEX)
- Multi-sectional mast
  - Low-head version
  - Giant drill version
  - Optimized transport length
- Upper mast extension 3 m (hydraulic foldable and lockable)
  - Simple and secure attachment, no working at heights unsecured
  - Reduced transport length
- Lattice mast extension for 20.5 m follow-up stroke
- Vario-mast head
  - Mast head for drill axis 1,000 mm, expandable to 1,400 mm
  - Increased stroke for Kelly bars when using an upper Kelly guide
  - Tilttable main jib for single-pass processes and optimized transport

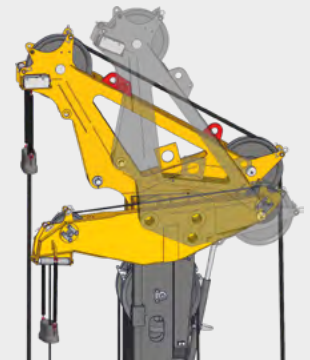

### Remote control for rigging the machine

- The remote control can be used to perform numerous rigging functions outside the danger zone, such as moving the drilling rig, telescoping the under carriage, etc.
  - Operation within sight of the controlled rigging functions
  - Rugged and compact wireless remote control Multi with LCD screen
  - Lockable storage box for the remote control can be accessed from the ground



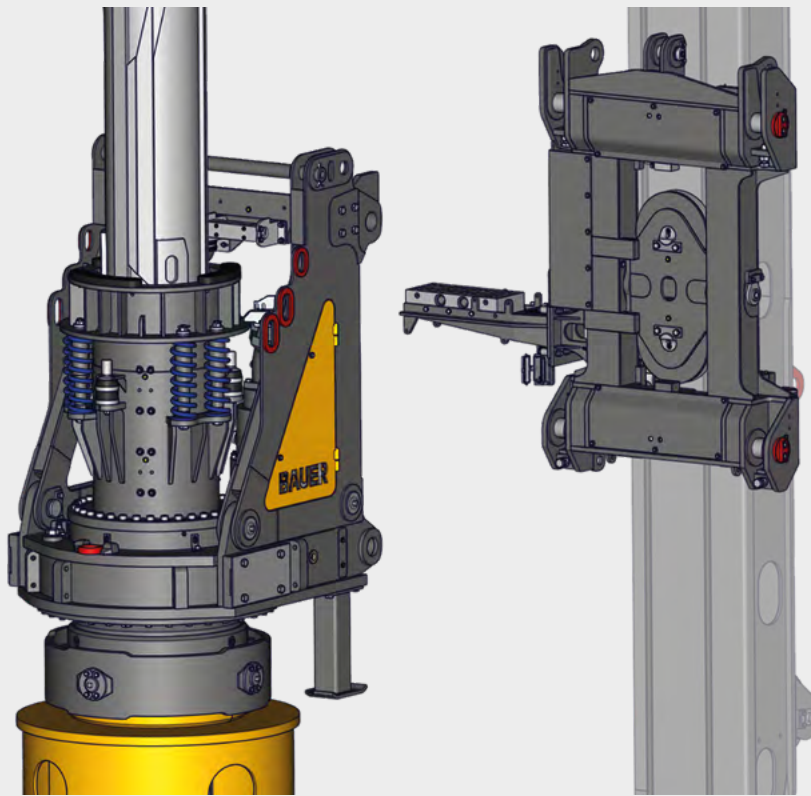

**Kelly set-up**

- Long Kelly guide
- Integrated shock absorbing spring system
- Kelly visualization (see page 11)
- Enhanced drilling performance
- High operation comfort
- Reduction of wear on Kelly bars and drive keys

**Rotary drive KDK 300**

- Optional single gear drive or multi gear drive
- Max. torque 300 kNm
- Max. speed 53 rpm
- Various modes of operation, partially selectable speed of rotation and torque

**Hydraulically operated pin connection on the crowd sledge**

- Pin connection controlled via the remote control
- Simple and secure attachment of the rotary drive, no working at heights unsecured

**KDK 300 S**

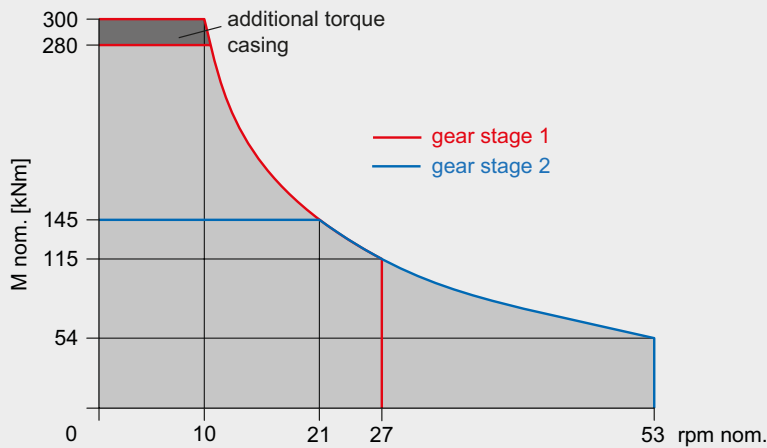

## Base carrier BT 85

**Standard**

- Removable counterweights
- Retractable grating steps next to the operator's cab
- Energy-efficient power (EEP)
- Premium operator's seat
- Cameras for rear area monitoring
- Integrated service platform
- Remote control Basic

**Optional**

- Counterweight, variably adjustable
- Guardrails on the upper level (foldable for transport)
- High-pressure cleaner with water tank
- Rear support unit
- Compressor 1,000 l/min
- Generator
- Low-temperature package / Low-temperature package plus
- Cab space heater with automatic timer
- Remote control Multi
- Operator seat with air-condition
- Weather protection

## Drilling rig attachments

**Standard**

- Main winch with hydraulic free-wheel control
- Swivel for main rope
- Masthead foldable for transport
- Pivoted anchor point for main and auxiliary rope

**Optional**

- Vario masthead
- Extension of drill axis to 1,400 mm
- Hydraulically operated pin connection on the crowd sledge for easy mounting and removal of the rotary drive
- Mast support
- Mast extension 3 m, hydraulically foldable and lockable
- Three-sectional mast for Low Head and Giant Drill applications
- Additional auxiliary winch 20 kN
- Attachment of casing oscillator up to BV 1500
- Auger cleaner attachment for Kelly system
- Passenger transportation system with car attachment

## Rotary drive

**Standard**

- Rotary drive KDK 300 S (multi-gear drive)
- Kelly drive adapter for outer Kelly tube 419 mm
- Integrated Kelly shock absorbing system
- Cardan joint

**Optional**

- Torque converter BTM 720 K for Kelly drilling
  - Torque 400 kNm (nominal)

## Measurement and control technology

**Standard**

- Automatic mast alignment with memory-recall
- Crowd speed control
- Feed rate control
- Electronic mast reach limiter
- Slewing Angle Warner

**Optional**

- Electronic load sensing for auxiliary winch
- Recording of concrete pressure and volume for Single-Pass processes
- Software modules for further applications
- Adaptive Kelly Speed assistant
- Automatic drilling and extraction control for Single-Pass processes
- BAUER Enhanced CAN Interface (BECI)
- Crowd Plus
- Stability Plus
- Slewing Angle Limiter

# B-TRONIC 5

Designed for you and ready for action.



## Dynamic

- Information that adapts to the respective process step
- Dynamic, situation adjusted screen layout
- Visualized position changes of drilling equipment for a clear process understanding

## Intuitive

- Intuitive menu navigation
- Help options on every page
- Focus on process-related information



Click now and learn **more about the powerful B-Tronic 5.**



## Personalized

- User-specific login available
- Use of existing set values
- Personalization of widgets

## Connected

- Interface to data recording
- Interface for service



**Stability Plus**

Stability Plus enables the permitted outreach to be extended, thereby enlarging the working range. To maintain the highest possible level of stability, the assistant automatically reduces the slewing speed of the uppercarriage within the extended outreach. In addition, the operator always has a perfect overview thanks to the visualization of the maximum permissible winch loads.



**Crowd Plus**

Crowd Plus supports the pulling and lifting of casings. Using the pulling plate between the drilling tool and the Kelly bar, the pulling force of the main winch is transferred to the crowd system. Through monitored and safely synchronized operation of the main winch and the crowd winch, even large diameters and heavy drilling equipment can be moved reliably.

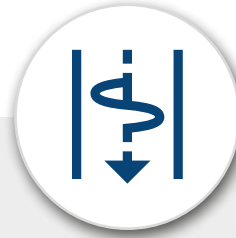

**Automatic Drilling and Extraction Control for Single Pass Processes**

The automatic system controls the drilling and extraction speed of the crowd system and enables hands-free operations. This ensures the installation of a high-quality pile while simultaneously keeping the concrete consumption at an optimum. Both automatic functions provide a stable, precise, and consistently uniform single-pass working process.

**Further Assistance Systems**

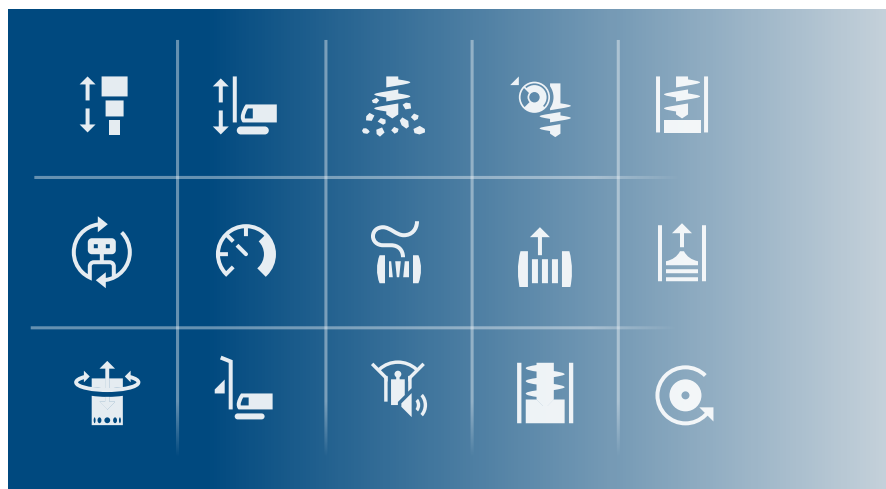



### Kelly Visualization

Kelly visualization makes working with the Kelly bar intuitive and transparent. It displays the locking recesses, the Kelly sections, the distance to the next section, and the spring travel – all in real time. The rapid approach of the locking position results in a significantly enhanced drilling performance. In addition, the wear on the Kelly bar and the drive keys is considerably reduced.



### Fill Level Assistant and Threshold Assistant

The fill level assistant monitors the fill level of the drilling tool and prevents over-drilling or overfilling. Color-coded indicators show the status; once the target value is reached, crowd and rotary drive stop automatically. The lead assistant monitors the lead between tool and casing and prevents advance drilling. When the threshold is reached, both drives stop. Both assistants can be combined.



### Automatic Torque Setting

The automatic torque setting limits the maximum torque to prevent excessive loading and any resulting damage to the drilling equipment. The operating limits of the installed tooling are taken over via the machine menu, and the system ensures that operation is carried out strictly within these limits.

- Kelly Drilling Assistant
- One-directional Spoil Discharge Assistant
- Bi-directional Spoil Discharge Assistant
- Slewing Angle Warner and Limiter
- Casing Assistant
- Auto Mast Alignment with Memory Function
- Slack Rope with Automatic Swivel Alignment
- etc.

**Discover more innovative assistance systems – click now!**



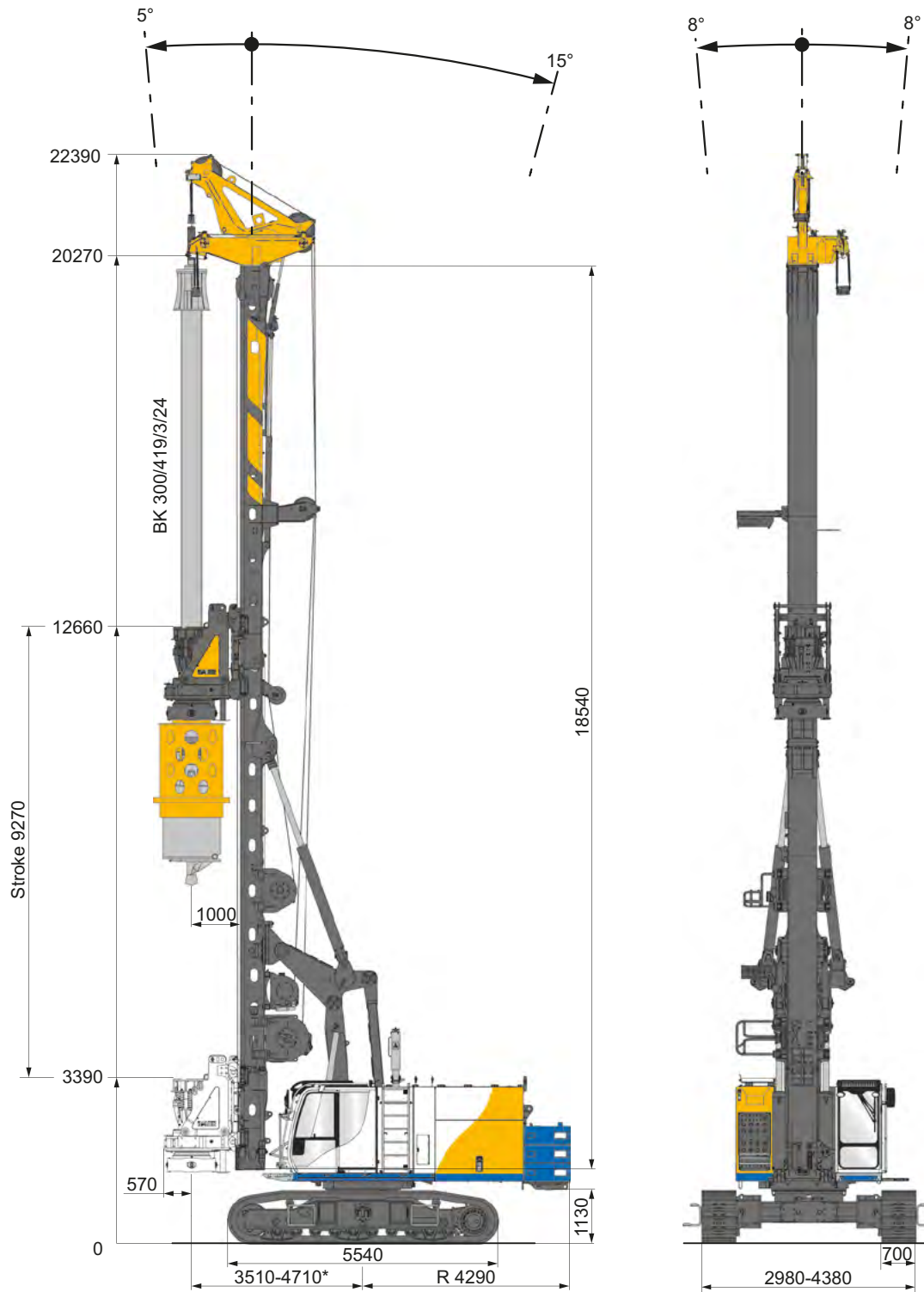

**Operating weight 85,0 t**  
(as shown)

\* depending on equipment

<b>Rotary drive (selectable)</b>		<b>KDK 300 S</b>	
Torque (nominal) for casing operation at 350 bar			300 kNm
Torque (nominal) for drilling at 350 bar			280 kNm
Max. speed of rotation			53 rpm
<b>Crowd winch</b>			
Max. sledge stroke with 3 m mast extension			18,700 mm
Crowded force push effective / nominal			330 / 423 kN
Crowded force pull effective / nominal			330 / 423 kN
Extraction force Crowd Plus effective / nominal with Mast support unit			545 / 638 kN
without Mast support unit			460 / 540 kN
Rope diameter			24 mm
Speed (down / up)			11.0 m/min
Fast speed (down / up)			35 m/min
<b>Main winch</b>		<b>M6 / L3 / T5</b>	
Line pull (1st layer) effective / nominal			215 / 270 kN
Rope diameter			28 mm
Line speed (max.)			85 m/min
<b>Auxiliary winch (selectable)</b>			
Line pull (1st layer) effective / nominal	80 / 100 kN		100 / 125 kN
Rope diameter			20 mm
Line speed (max.)			55 m/min
<b>Base carrier (EEP)</b>		<b>BT 85</b>	
Engine			Volvo TAD 13
Rated output ISO 3046-1	345 kW @ 1,700 rpm		405 kW @ 1,700 rpm
Exhaust emission	UN/ECE R96*		EU Stage V EPA/CARB Tier 4 final
Diesel tank capacity / AdBlue Tank	730 / - l		730 / 70 l
Sound pressure level in the cabin (EN 16228, Annex B)			LP <sub>A</sub> 80 dB (A)
Sound power level (2000/14/EC u. EN 16228, Annex B)			LW <sub>A</sub> 108 dB (A)
Hydraulic pressure			350 bar
Hydraulic oil tank capacity			650 l
Flow rates			2 x 320 + 1 x 565 + 1 x 215 l/min
<b>Under carriage</b>		<b>UW 85</b>	
Crawler type			B 7
Traction force effective / nominal			546 / 643 kN

\* Exhaust emission equivalent EPA Tier 3 und EU Stage III A

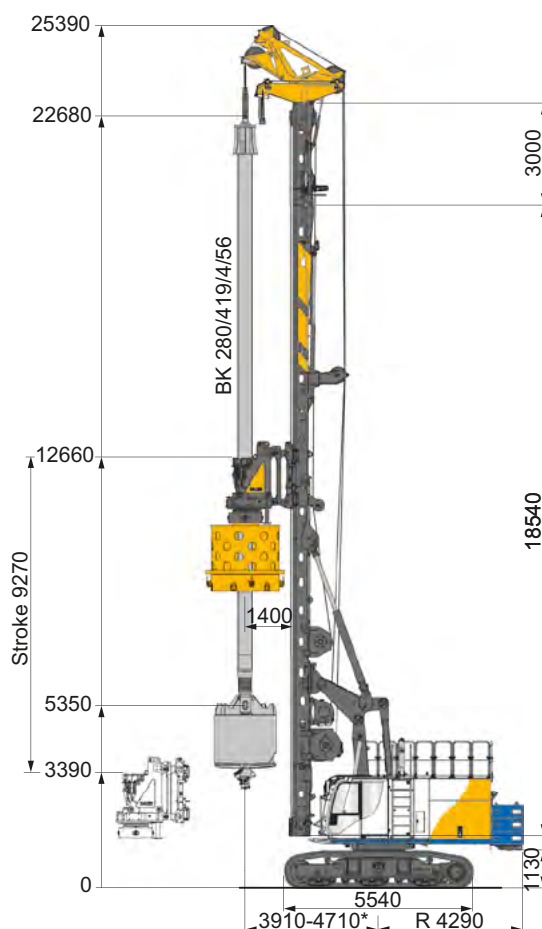
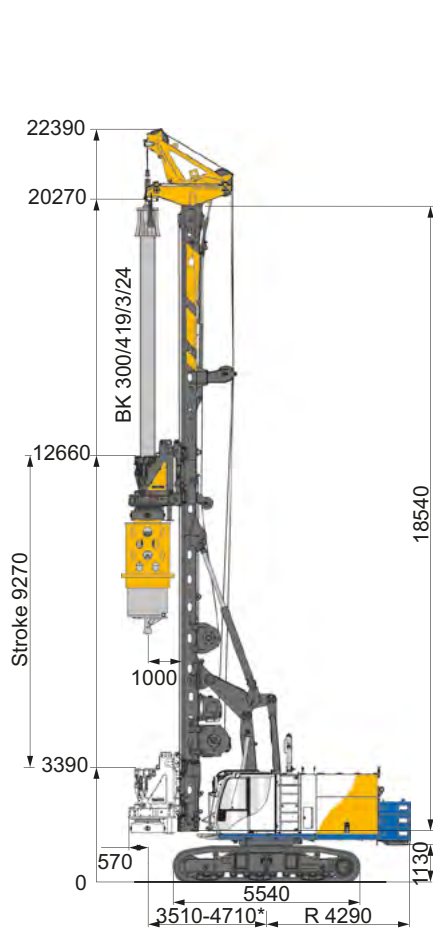

	Basic version	Upgraded version
Mast extension	without	3 m
Drill axis	1,000 mm	1,400 mm
Max. drilling diameter		
uncased	1,700 mm	2,500 mm
cased	1,400 mm	2,200 mm
Operating weight, approx.	85.0 t	102.9 t
with Kelly	3/24	4/56
with casing drive adapter	1,300 mm	2,000 mm
with bucket	1,180 mm	1,830 mm
with counterweight*	9.9 t	14.7 t

\* depending on equipment

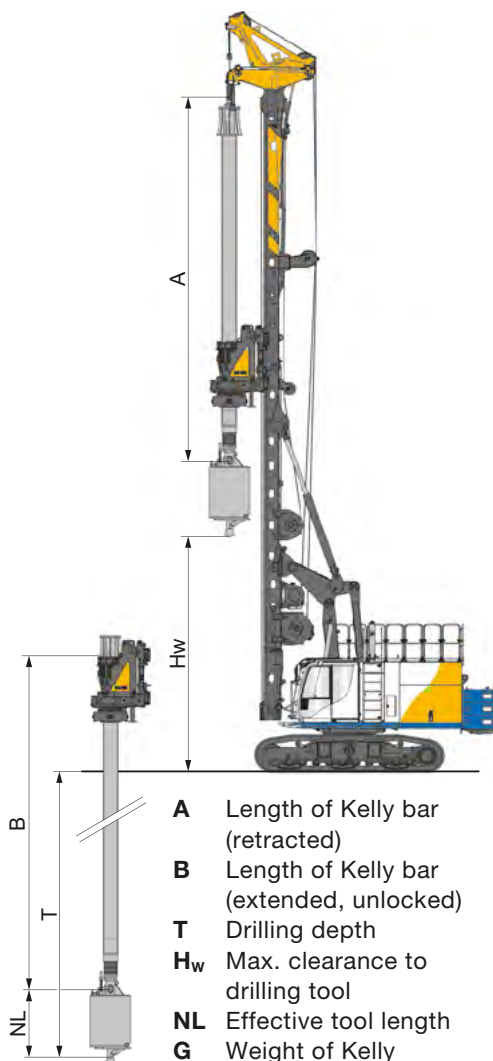

### Drilling depth – uncased Kelly drilling, drill axis 1,000 mm

				without mast extension	3.0 m mast extension		
<b>3-part Kelly</b>	A (m)	B (m)	G (kg)	H <sub>w</sub> (m)	T (m)	H <sub>w</sub> (m)	T (m)
BK/300/419/3/24	10.7	26.4	5,500	7.4	24.9	7.9	24.9
BK/300/419/3/27	11.7	29.4	5,900	6.4	27.9	7.9	27.9
BK/300/419/3/30	12.7	32.4	6,350	5.4	30.9	7.9	30.9
BK/300/419/3/33	13.7	35.4	6,800	4.4	33.9	7.4	33.9
BK/300/419/3/36	14.7	38.4	7,200	3.4	36.9	6.4	36.9
BK/300/419/3/39	15.7	41.4	7,700	2.4	39.9	5.4	39.9
<b>4-part Kelly</b>							
BK/280/419/4/36	12.3	38.2	8,350	5.7	36.7	7.9	36.7
BK/280/419/4/40	13.3	42.2	8,950	4.7	40.7	7.7	40.7
BK/280/419/4/44	14.3	46.2	9,600	3.7	44.7	6.7	44.7
BK/280/419/4/48	15.3	50.2	10,300	2.7	48.7	5.7	48.7
BK/280/419/4/56	17.3	58.2	11,550	0.7	56.7	3.7	56.7
BK/280/419/4/64	19.3	66.2	12,800	-	64.7	1.7	64.7

Drilling data have been determined with an effective tool length of NL = 1.9 m and with the mast at a minimum operating radius. These data only apply for the use of Bauer tools.

Other drilling depths, drilling diameters and Kelly versions are available on request.

### Torque multiplier BTM 720 for a torque of 400 kNm for casing

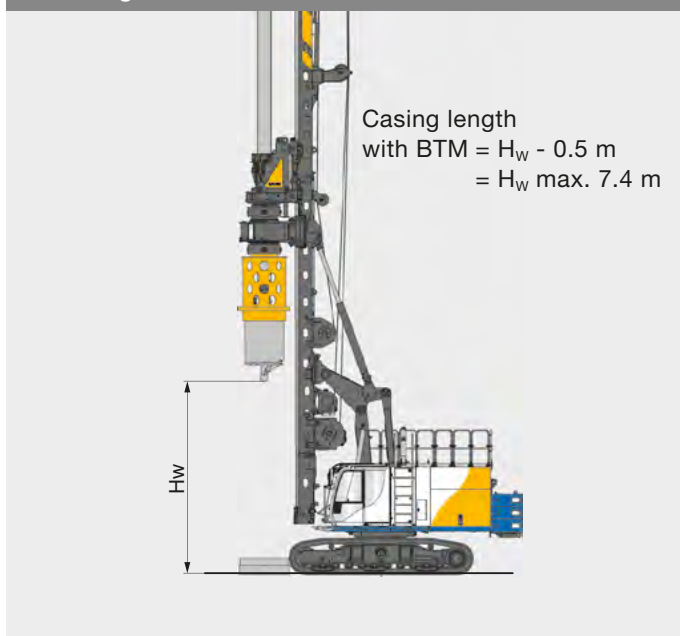

### Kelly drilling with casing oscillator up to BV 1500

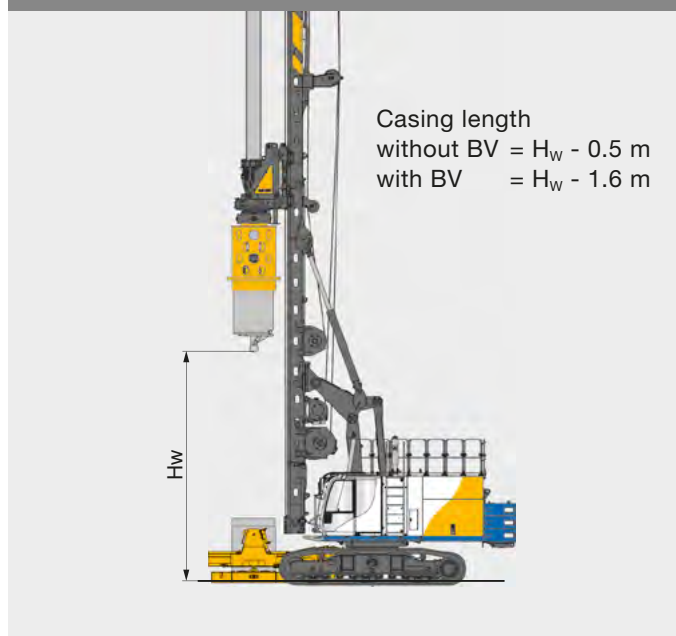

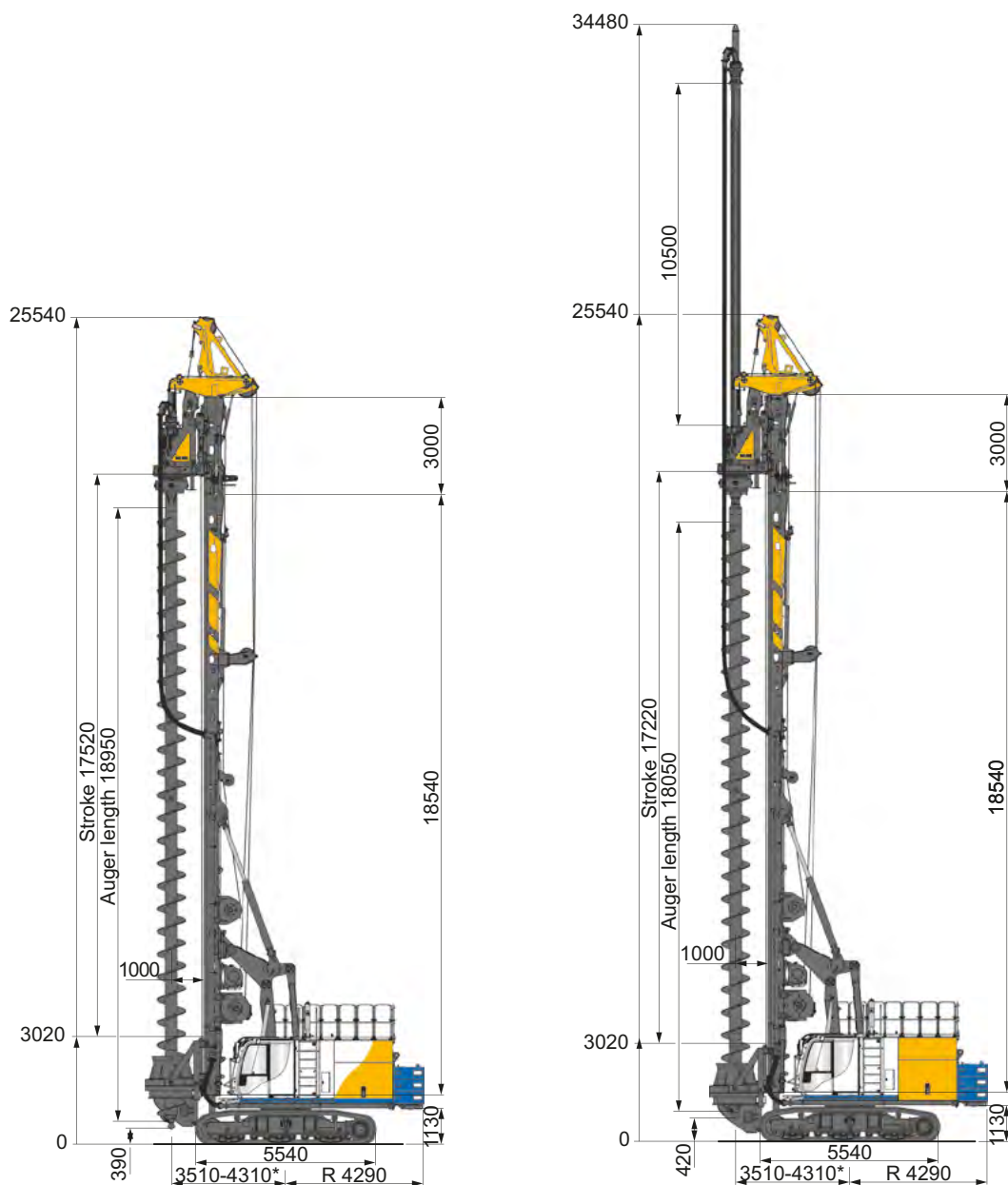

	without kelly extension	with kelly extension
Mast extension	3 m	3 m
Kelly extension	without	10.5 m
Max. drilling diameter	1,200 mm	1,200 mm
Drilling depth with Bauer rotary auger cleaner	16.9 m	27.6 m
Drilling depth with Bauer brush auger cleaner	17.9 m	28.4 m
Max. extraction force with main and crowd winch (effective)	730 kN	730 kN
with counterweight*	12.3 t	12.3 t

\* depending on equipment



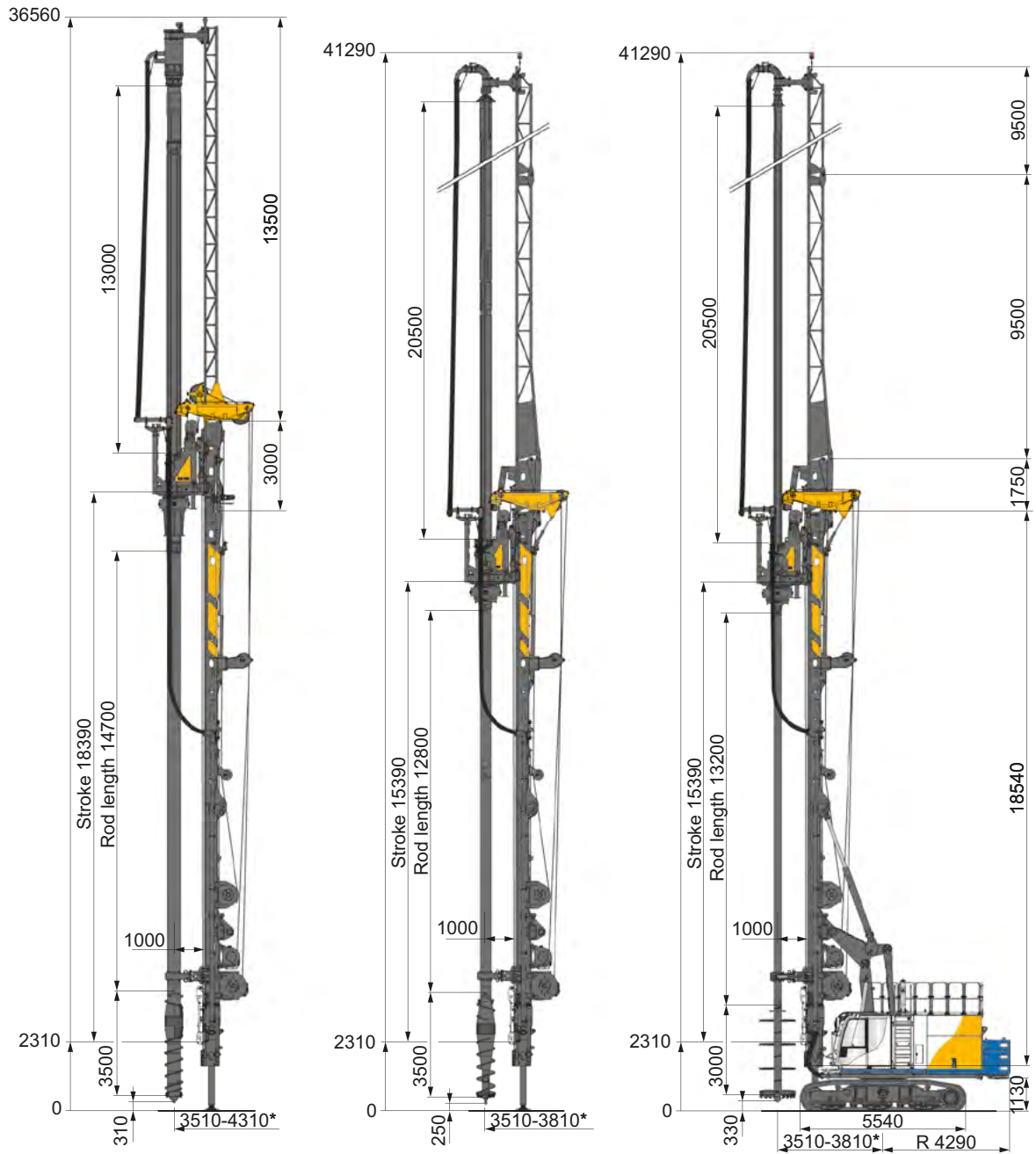

	FDP Lost-bit drilling	FDP drilling	SCM mixing
Mast extension	3 m	-	-
Kelly extension	13.0 m	20.5 m	20.5 m
Max. drilling diameter FDP	620 mm	620 mm	-
Max. mixing diameter SCM	-	-	2,500 mm**
Max. drilling depth FDP	30.7 m	34.8 m	-
Max. mixing depth SCM	-	-	34.8 m
Max. extraction force with main and crowd winch (effective)	730 kN	730 kN	730 kN
with counterweight*	14.7 t	12.3 t	12.3 t

\* depending on equipment

\*\* operation only possible with restrictions



### Highlights Extension Package Single Pass Extreme (SPEX)

- Expansion of the active feed by 7.7 m due to installation of an upper mast extension
- Further 8 m drilling depth, achievable due to following up with the Kelly extension
- Low investment costs due to the expansion of the standard equipment
- Compact transport dimensions due to the hydraulically foldable and lockable mast extension
- Optionally, the Remote Control Multi can be used to fold the mast extension
- Can be used in CFA, FDP and SCM mode

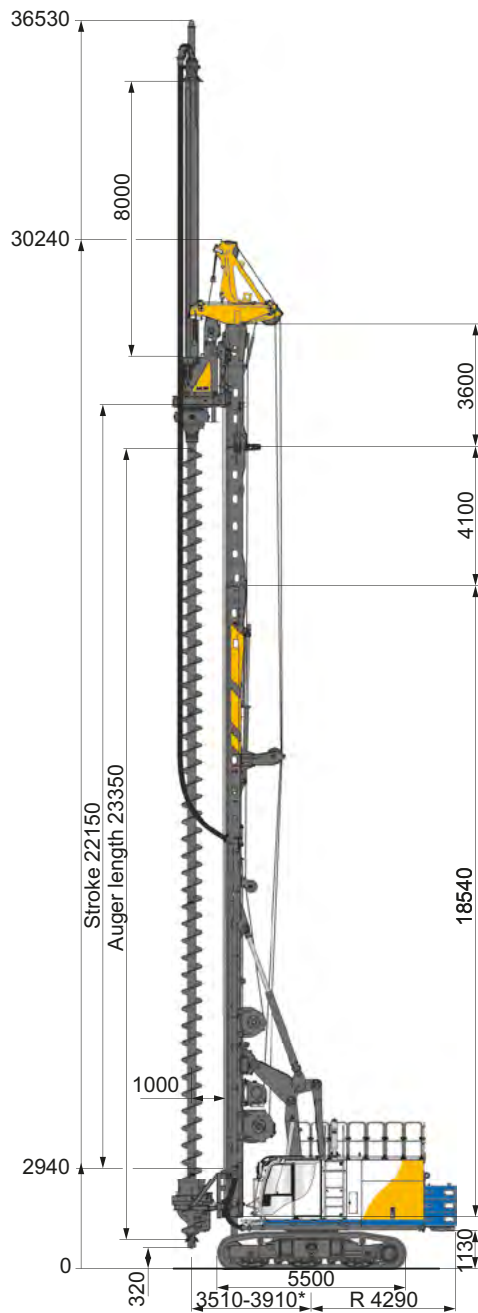

	CFA drilling		FDP drilling	SCM mixing
Kelly extension	without	8.0 m	8.0 m	8.0 m**
Max. drilling / mixing diameter	1,200 mm	880 mm	620 mm	1,700 mm
Max. drilling depth with Bauer rotary auger cleaner and Kelly extension	29.8 m		-	-
Max. drilling depth with Bauer brush auger cleaner and Kelly extension	31.0 m		-	-
Max. drilling / mixing diameter with casing guidance and Kelly extension	-		30.1 m	30.1 m
Max. extraction force with main and crowd winch (effective)*	565 kN		565 kN	565 kN
with counterweight*	14.7 t		14.7 t	14.7 t

\* depending on equipment  
 \*\* not recommended

### Highlights of Handling Package for FDP Lost-Bit:

- Special mast head with auxiliary rope boom, which can be swivelled hydraulically in the drill axis
- Mast-guided personal hoist system with swivelling transport platform
- Concrete funnel with camera system and cleaning system on the rotary drive for de-pressurized concreting in FDP mode
- High-pressure cleaner with water tank integrated in the base carrier
- Hydraulic upper carriage support for stabilizing and lifting the machine
- Extra wide flat track shoes on the under carriage
- Advanced EEP hydraulic system for full parallel operation of drilling and auxiliary functions
- Large horizontal movement enables a smooth and trouble-free swivel motion

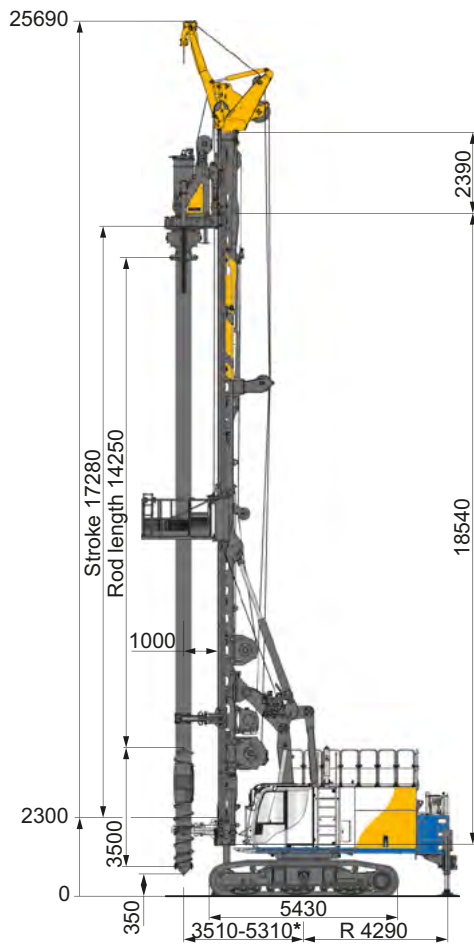

**Operating weight 94.3 t**  
(as shown)

	FDP Lost-Bit drilling Handling Package
Max. drilling diameter	620 mm
Max. drilling depth	16.8 m
Max. extraction force with main and crowd winch (effective)	730 kN
with counterweight*	12.3 t

\* depending on equipment

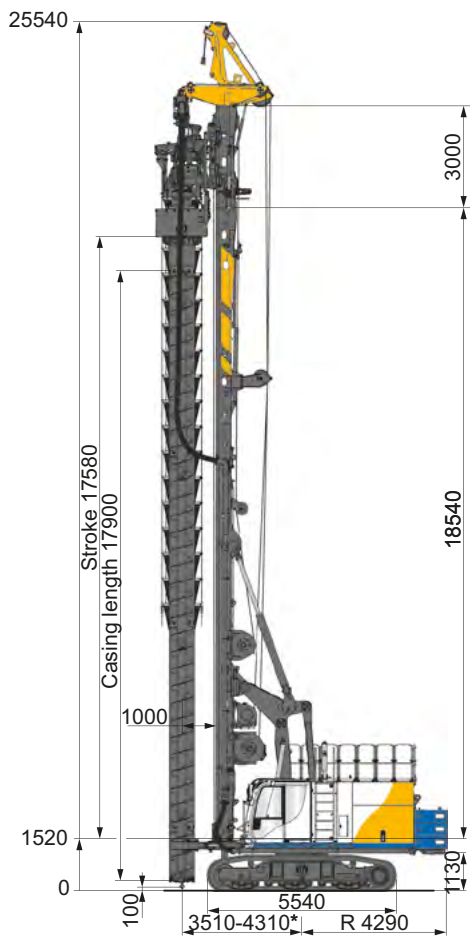

CCFA with FoW application DKS 100/200**		Vibro Displacement (VD) Vibrator TR 17	
Torque auger/casing	100/200 kNm	Max. penetration depth	16.1 m
Mast extension	3 m	Pressure with crowd winch (effective)	110 kN
Max. drilling diameter	750 mm	Max. extraction force with crowd winch (effective)	330 kN
Max. drilling depth	17.3 m	with counterweight*	14.9 t
Max. extraction force with main and crowd winch (effective)	730 kN		
Ejection system with counterweight*	optional 12.3 t		

\* depending on equipment  
 \*\* DKS 50/140 available

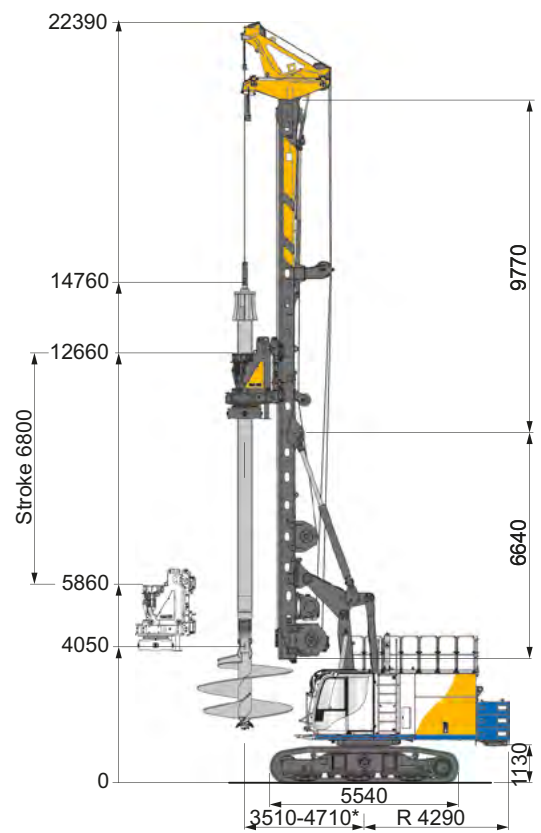
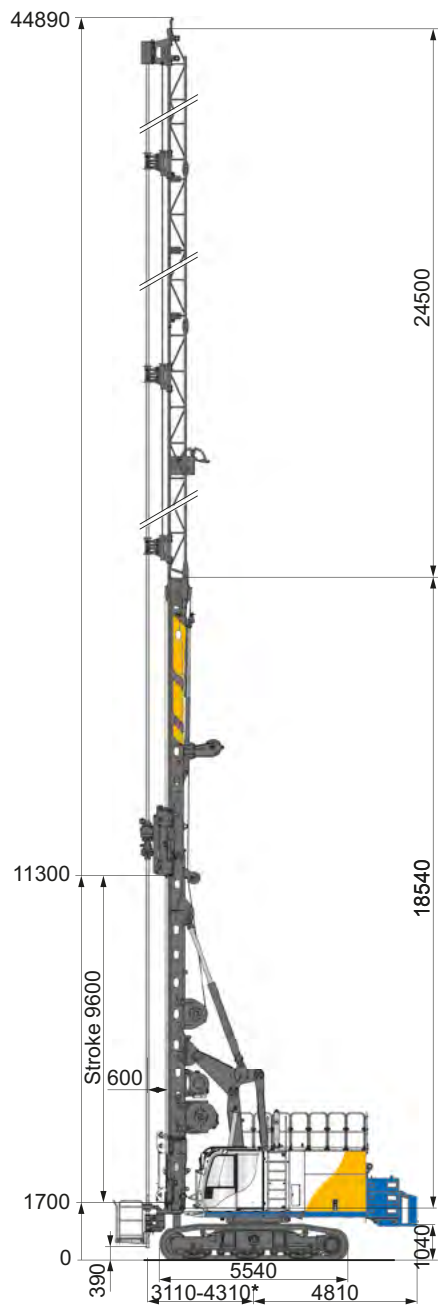

Jet Grouting	
Length of lattice mast	24.5 m
Max. rod diameter	89 - 133 mm
Max. jetting depth	35.3 m
Rotary drive	KDK 10/14 S
Max. extraction force with crowd winch (effective)	330 kN
with counterweight*	12.3 t

Giant Drill	
Lower mast extension	without
Max. drilling diameter	3,800 mm

\* depending on equipment

### Low Headroom System for large drilling depths:

- The BG 30 H low headroom drilling rig can also be configured for large drilling depths in limited headroom conditions.
- With the special Kelly bar BK-LH 120/610/8/35 drilling depths of up to 35.3 m can be achieved with a maximum drilling diameter of 2,500 mm.
- Equipped with the low headroom masthead, the rig has a minimum height of just 8.8 m. Alternatively, the height of the rig with the Kelly masthead is 10.8 m.
- The KDK 300 WP (max. 280 kNm for drilling) automatically reduces the torque to 120 kNm when the special Kelly bar BK-LH 120/610/8/35 is used. The full torque of 300 kNm is provided for cased drilling.

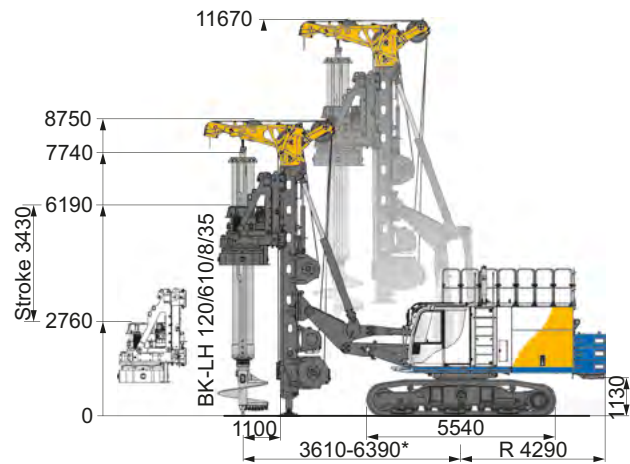
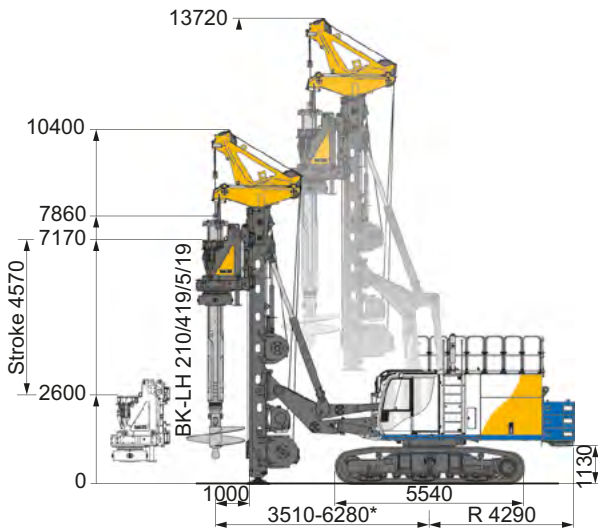
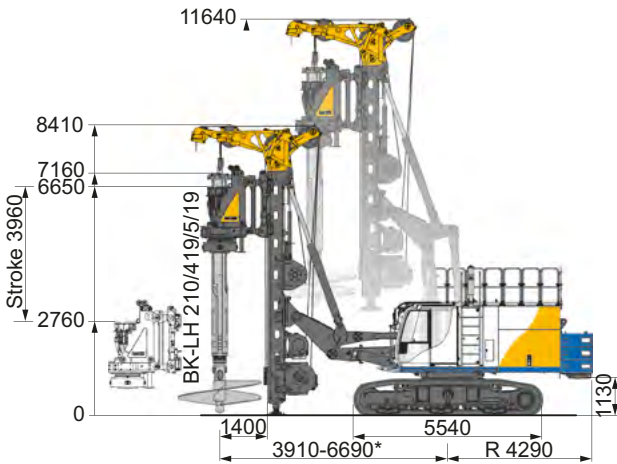

	Low Headroom System
Lower mast extension	without
Drill axis	1,000 / 1,400 mm
Max. drilling diameter	1,700 / 2,500 mm
Max. drilling depth	19.5 m

	Low Headroom System for large drilling depth	
Rotary drive	KDK 300 WP	
Drill axis	1,100 mm	1,400 mm
Max. drilling diameter	1,900 mm	2,500 mm
Max. drilling depth (BK-LH 120/610/8/35)	35.3 m	

\* depending on equipment

**G** = Weight  
**B** = Width, overall

Weights shown are approximate values; optional equipment may change the overall weight and dimensions.

**Transport with under carriage**

**Without mast extension\***

**G = 61.5 t**

**G = 73.8 t with 12.3 t counterweight**

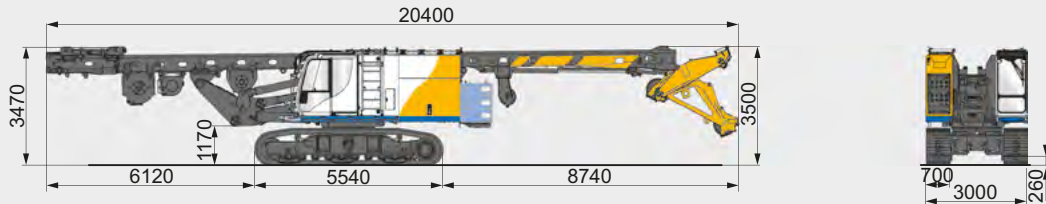

**With mast extension\***

**G = 64.5 t**

**G = 76.8 t with 12.3 t counterweight**

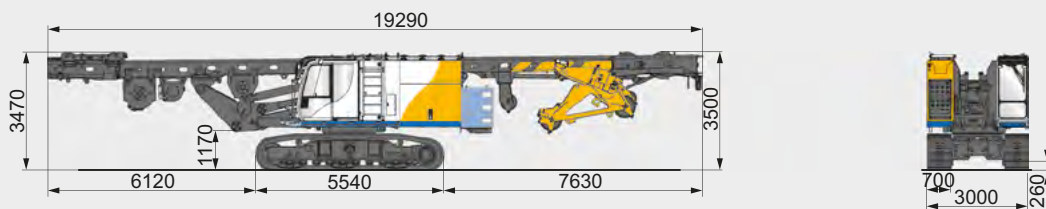

**Lower mast section with rotary drive and folded mast extension**

**G = 70.0 t with rotary drive**

**G = 82.3 t incl. rotary drive with 12.3 t counterweight**

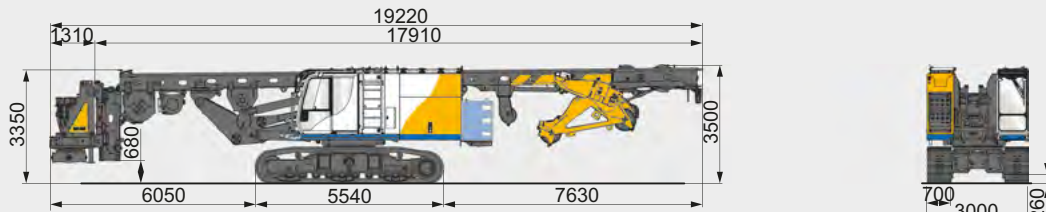

**Extension Package Single Pass Extreme (SPEX)**

**G = 65.5 t**

**G = 80.2 t with 14.7 t counterweight**



**Counterweight\*\***

**G = 2 x 4,9 t + 1 x 2,5 t**  
**B = 3,000 mm**



**Rotary drive**

**G = 5.5 t (KDK 300 S)**



**Track shoes**

**Overall width of crawlers retracted / extended**

700 mm	3,000 - 4,400 mm
800 mm	3,300 - 4,500 mm
900 mm	3,400 - 4,600 mm

\* more weight with three-sectional mast approx. 500 kg

## International Service Hotline

**+800 1000 1200\***

**+49 8252 97-2888**

**BMA-Service@bauer.de**

\*toll-free number, where available

**24/7**



**BAUER Maschinen GmbH**  
**BAUER-Strasse 1**  
**86529 Schrobenhausen**  
**Germany**  
**Phone: +49 8252 97-0**  
**bma@bauer.de**  
**www.bauer.de**

Design developments and process improvements may require the specification and materials to be updated and changed without prior notice or liability. Illustrations may include optional equipment and not show all possible configurations. These and the technical data are provided as indicative information only, with any errors and misprints reserved.